

Washer with Dual Arm Robot

Capability Twice

Automatic Loading / Unloading

Detachable Hand

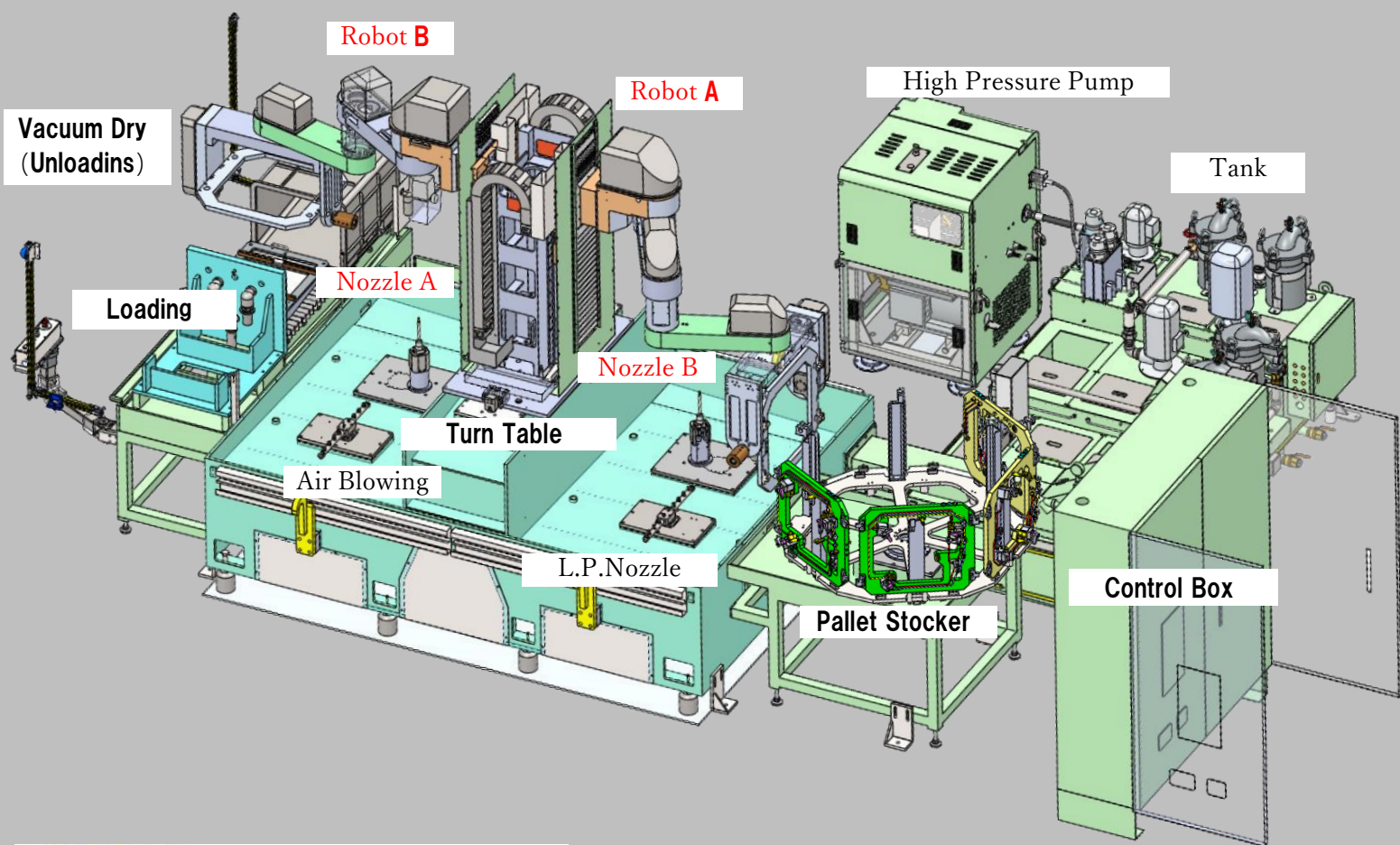

MOVAC LTD

R&D Office (Japan)

〒938-0162 #3889Yamazaki, Asahi-machi

Shimoniikawa-gun, Toyama

TEL+81-90-9447-8553 FAX +81-765-84-8033

FE - MOVAC

R&D Manufacturing Base (China)

Shanghai FE-MOVAC Precision Machine Ltd.

NO.268, YuanKangRoad, BaoShanDistrict, Shanghai.

TEL +86-21-36160880 FAX +86-21-36160892

<http://www.fe-movac.com>

FE-Movac, Inc

43938 Plymouth Oaks Blvd

Plymouth, MI 48170

TEL (734) 927-6064 FAX (866)727-1216

CELL (847) 840-3439 (Jeff Yunker)

DISTRIBUTOR:

TEXMAC INC.

5555 Oakbrook Parkway

Norcross, GA 30093

CELL (470) 349-4277(Takumi Kimoto)



FE-MOVAC Catalog

MOVAC=Most Valuable Concept

FE-MOVAC

Over View

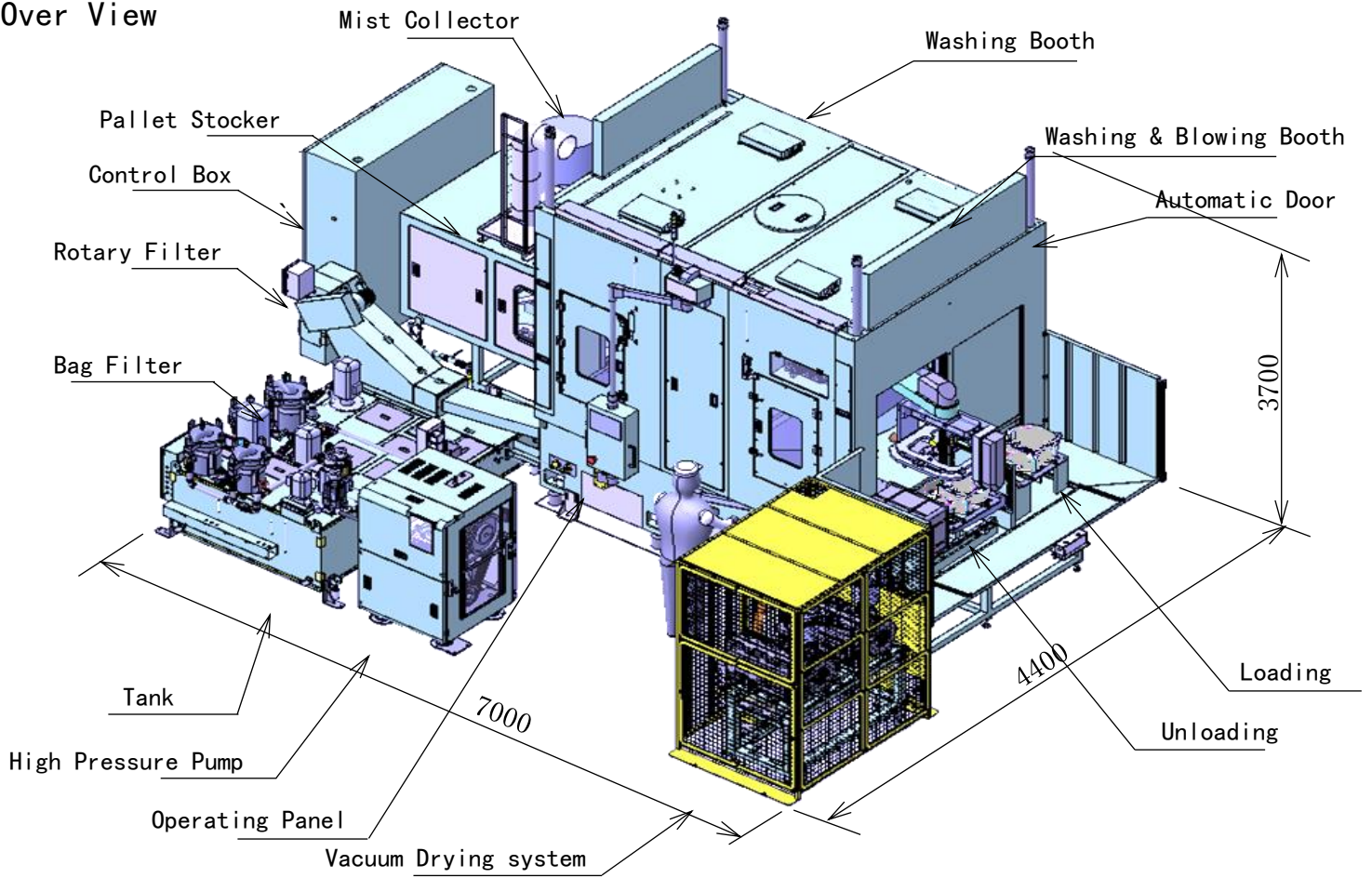

Specification

Item	Specification
Type	F22
H.P. Pump	50MPa x 20L/min
H.P.Control	E-Pressure Control
Traverce(mm)	X=700, Y=550 , Z=550(Reference)
Max.Speed	48m/min
Spindle Spd.	500min ⁻¹
H.P. Nozzle	2 pcs.
L.P. Nozzle	1 set
Robot type	GR65V (CNC 5-axis) x 2pcs.
CNC type	FANUC 31i
Filter system	Rotary Filter (#50) + Bag Filter (10μ) + Bag Filter (5μ)
Accessory	Oil Separator, Mist Collector Lighting in booth Vacuum Drying system
Weight	8.5T
E.Cappacity	84KVA

Waterjet detecting



Speed Flex Nozzle

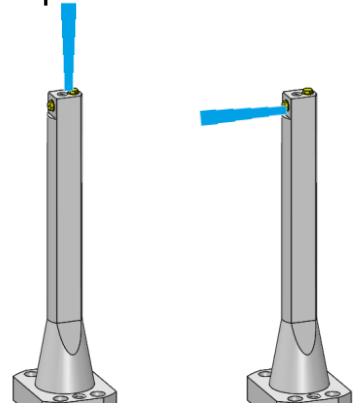

E-Pressure Control

Surface 35MPa → Oil Hole 50MPa → Thread 15MPa

